



# FIRE DETECTION DESIGN BASED ON GAS LEAKAGE ACCOMPANIED BY FIRE LOCATION POINT USING ESP32 BASED ON IOT

## TUGAS AKHIR

Ditentukan Sebagai Salah Satu Syarat Memperoleh Gelar Sarjana Teknik pada Program Studi Teknik Elektro Fakultas Sains dan Teknologi

Elektro Fakultas Sains dan Teknologi



Oleh :

**NANDA WIBOWO**

**12050512889**

**PROGRAM STUDI TEKNIK ELEKTRO**

**FAKULTAS SAINS DAN TEKNOLOGI**

**UNIVERSITAS ISLAM NEGERI SULTAN SYARIF KASIM**

**PEKANBARU**

**2024**

© Hak cipta milik UIN Suska Riau

Hak Cipta Dilindungi Undang-Undang

1. Barang mengutip sebagian atau seluruh karya tulis ini tanpa mencantumkan dan menyebutkan sumber:
  - a. Pengutipan hanya untuk kepentingan pendidikan, penelitian, penulisan karya ilmiah, penyusunan laporan, penulisan kritik atau tinjauan suatu masalah.
  - b. Pengutipan tidak merugikan kepentingan yang wajar UIN Suska Riau.
2. Dilarang mengumumkan dan memperbanyak sebagian atau seluruh karya tulis ini dalam bentuk apapun tanpa izin UIN Suska Riau.



State Islamic University of Sultan Syarif Kasim Riau



## LEMBAR PERSETUJUAN

### ***FIRE DETECTION DESIGN BASED ON GAS LEAKAGE ACCOMPANIED BY FIRE LOCATION POINT USING ESP32 BASED ON IOT***

#### **TUGAS AKHIR**

oleh:

**NANDA WIBOWO**  
**12050512889**

Telah diperiksa dan disetujui sebagai laporan Tugas Akhir Program Studi Teknik Elektro di Pekanbaru, pada tanggal 16 Mei 2024

**Ketua Prodi Teknik Elektro**

**Dr. Zulfatri Aini, S.T., M.T**  
**NIP. 19721021 200604 2 001**

**Pembimbing**

**Hilman Zarory, S.T., M.Eng**  
**NIP. 19870508 501903 1 006**

1. Dilarang mengutip sebagian atau seluruh karya tulis ini tanpa mencantumkan dan menyebutkan sumber:
  - a. Pengutipan hanya untuk kepentingan pendidikan, penelitian, penulisan karya ilmiah, penyusunan laporan, penulisan kritik atau tinjauan suatu masalah.
  - b. Pengutipan tidak merugikan kepentingan yang wajar UIN Suska Riau.
2. Dilarang mengumumkan dan memperbanyak sebagian atau seluruh karya tulis ini dalam bentuk apapun tanpa izin UIN Suska Riau.



# LEMBAR PENGESAHAN

## ***FIRE DETECTION DESIGN BASED ON GAS LEAKAGE ACCOMPANIED BY FIRE LOCATION POINT USING ESP32 BASED ON IOT***

### TUGAS AKHIR

oleh :

**NANDA WIBOWO**  
**12050512889**

Telah dipertahankan di depan Sidang Dewan Penguji sebagai salah satu syarat untuk memperoleh gelar Sarjana Teknik Fakultas Sains dan Teknologi Universitas Islam Negeri Sultan Syarif Kasim Riau di Pekanbaru, pada tanggal 16 Mei 2024

Pekanbaru, 16 Mei 2024

Mengesahkan,

**Dekan Fakultas Sains dan Teknologi**

**Ketua Prodi Teknik Elektro**

**Dr. Hartono, M.Pd**  
**NIP. 19640301 199203 1 003**

**Dr. Zulfatri Aini, S.T., M.T**  
**NIP. 19721021 200604 2 001**

### DEWAN PENGUJI:

- Ketua** : Arif Marsal, Lc., M.A
- Sekretaris** : Hilman Zarory, S.T., M.Eng
- Anggota 1** : Dian Mursyitah, S.T., M.T
- Anggota 2** : Aulia Ullah, S.T., M.Eng

© Hak cipta milik UIN Suska Riau

State Islamic University of Sultan Syarif Kasim Riau

Hak Cipta Dilindungi Undang-Undang

1. Dilarang mengutip sebagian atau seluruh karya tulis ini tanpa mencantumkan dan menyebutkan sumber.
- a. Pengutipan hanya untuk kepentingan pendidikan, penelitian, penulisan karya ilmiah, penyusunan laporan, penulisan kritik atau tinjauan suatu masalah.
- b. Pengutipan tidak merugikan kepentingan yang wajar UIN Suska Riau.
2. Dilarang mengumumkannya dan memperbanyak sebagian atau seluruh karya tulis ini dalam bentuk apapun tanpa izin UIN Suska Riau.





Nomor

: 25/2021

Tanggal

: 10 September 2021

**SURAT PERNYATAAN**

Saya yang bertanda tangan di bawah ini:

: Nanda Wibowo

: 12050512889

Tempat/Tgl. Lahir

: Duri, 05 Maret 2002

Prodi

: Sains dan Teknologi

Prodi

: Teknik Elektro

Judul Skripsi

:

***FIRE DETECTION DESIGN BASED ON GAS LEAKAGE ACCOMPANIED BY FIRE LOCATION POINT USING ESP32 BASED ON IOT***

Menyatakan dengan sebenar-benarnya bahwa :

1. Penulisan Skripsi dengan judul sebagaimana tersebut di atas adalah hasil pemikiran dan penelitian saya sendiri.
2. Semua Kutipan pada Karya tulis saya ini sudah disebutkan sumbernya.
3. Oleh karena itu Skripsi saya ini, saya nyatakan bebas dari plagiat.
4. Apa bila dikemudian hari terbukti terdapat plagiat dalam penulisan Skripsi saya tersebut, maka saya bersedia menerima sanksi sesuai peraturan perundang-undangan.

Demikianlah surat pernyataan ini saya buat dengan penuh kesadaran dan tanpa paksaan dari pihak manapun juga.

UIN SUSKA RIAU

Pekanbaru, 20 Mei 2024

Yang membuat pernyataan



Nanda Wibowo

NIM.12050512889

Hak cipta milik UIN Suska Riau  
 Tidak Cipta Dilindungi Undang-Undang  
 2. Dilarang mengutip, sebagian atau seluruhnya, atau membuat karya tulis lain tanpa mencantumkan dan menyebutkan sumber:  
 a. Pengutipan hanya untuk kepentingan pendidikan, penelitian, penulisan karya ilmiah, penyusunan laporan, penulisan kritik atau tinjauan suatu masalah.  
 b. Pengutipan tidak merugikan kepentingan yang wajar UIN Suska Riau.  
 2. Dilarang mengumumkan dan memperbanyak sebagian atau seluruh karya tulis ini dalam bentuk apapun tanpa izin UIN Suska Riau.

# Fire Detection Design Based on Gas Leakage Accompanied by Fire Location Point Using ESP32 Based on IoT

**Nanda Wibowo**

Electrical Engineering  
 Sultan Syarif Kasim Riau State Islamic University,  
 Pekanbaru, Indonesia  
[nandawibowo2002@gmail.com](mailto:nandawibowo2002@gmail.com)

**Dian Mursyitah, S.T., M.T**

Electrical Engineering  
 Sultan Syarif Kasim Riau State Islamic University,  
 Pekanbaru, Indonesia  
[DMursyitah@gmail.com](mailto:DMursyitah@gmail.com)

**Hilman Zarory, S.T., M.Eng**

Electrical Engineering  
 Sultan Syarif Kasim Riau State Islamic University,  
 Pekanbaru, Indonesia  
[hilman.zarory@uin-suska.ac.id](mailto:hilman.zarory@uin-suska.ac.id)

**Aulia Ullah, S.T., M.Eng**

Electrical Engineering  
 Sultan Syarif Kasim Riau State Islamic University,  
 Pekanbaru, Indonesia  
[auliaullah@yahoo.co.id](mailto:auliaullah@yahoo.co.id)

**Abstract** – Type B fires are fires that occur due to the burning of fuel in the form of gas, this type of fire occurs quite often where in DKI Jakarta this type of fire occurs up to 180 cases and one of the causes of this fire is due to LPG gas leaks then at this time the fire extinguisher only has 1 method to find the location of the fire, therefore in this research a tool was created that can detect gas leaks and fires which can send danger warning messages to users, namely building owners and firefighters via the telegram application, from research carried out by the tool created to successfully detect the presence of gas leaks when the PPM value of LPG gas exceeds 100 PPM as well as fires when the presence of fire is detected, the carbon dioxide value in smoke exceeds 100 PPM, and also high temperatures, the tool will identify dangerous conditions and send a danger warning message to the user along with the coordinates and Google Maps link for the location of the equipment when a fire occurs.

**Keywords:** Fire, Gas Leak, Internet of Things, ESP32, Telegram



[Creative Commons Attribution-NonCommercial-ShareAlike 4.0 International License.](https://creativecommons.org/licenses/by-nc-sa/4.0/)

## I. INTRODUCTION

Fire is a sudden, undesirable incident where the emergence of unwanted and uncontrolled fire has consequences for human life and also material loss [1]. Fires can occur when a heat source reaches a critical temperature and undergoes a chemical reaction with oxygen [2]. Fires have 4 classifications, namely, class A fires which are caused by the burning of non-metallic solid objects, class B which are caused by the burning of liquid fuel or unwanted gas, class C which is caused by electrical voltage, and class D which is caused by fuel. in the form of metal [3].

Type B fires are fires that occur quite frequently, in 2020 in the DKI Jakarta province there were 180 cases

of this type of fire recorded [4]. One of the causes of this type of fire is a gas leak *Liquefied Petroleum Gas* (LPG) which is a type of fuel commonly used by the public where gas leaks that occur are often caused by a lack of attention to the use of LPG gas such as errors in installing the regulator, using an inappropriate gas hose or because the safety layer on the LPG cylinder is no longer in good condition. which is good [5].

Therefore, more attention is needed regarding one of the causes of type B fires so that type B fires can be prevented before they occur. Several studies have previously been carried out on this matter, one of which is research that produces an LPG gas leak detector which is equipped with a danger warning message via *Short Message Service* (SMS) [6], then this research was developed where danger warning messages were sent via the Telegram messaging application [7][8].

Even though the cause of a type B fire can be detected, there is a possibility that a fire can occur before preventative action is taken, therefore further action is needed if a fire occurs and regarding this there is research that has produced a fire detection device that can send a fire warning message to the owner. building via the Telegram messaging application [9].

Furthermore, regarding further action in the event of a fire, the fire department as a party that can anticipate fires is currently very limited, this is known based on the author's interview with the Riau Fire Regional Disaster Management Agency (BPBD) where it was stated that to find the location of the fire currently the fire brigade is very dependent on telephone calls to the community around the location of the fire, the Riau Fire BPBD stated that when a fire occurs, the general procedure is that residents around the location of the fire will contact the local fire department and when the fire department receives the

Hak Cipta Dilindungi Undang-Undang  
 1. Dilarang mengutip sebagian atau seluruh karya tulis ini tanpa mengutip sumbernya.  
 a. Pengutipan hanya untuk kepentingan pendidikan, penelitian, penulisan karya ilmiah, penyusunan laporan, penulisan kritik atau tinjauan suatu masalah.  
 b. Pengutipan tidak merugikan kepentingan yang wajar UIN Suska Riau.  
 2. Dilarang mengemukakan dan memperbanyak sebagian atau seluruh karya tulis ini dalam bentuk apapun tanpa izin UIN Suska Riau.



call, the reporter will describe the location of the fire, but sometimes the location description provided is ambiguous so it can raise doubts about the exact location of the fire.

Therefore, based on the details above, the author conducted research which produced a tool that aims to prevent the occurrence of type B fires, namely fires that occur due to the burning of gaseous fuel by detecting the presence of a gas leak and notifying the user, namely the building owner, so that the user can take preventive action before a fire occurs and if the user does not have time to take preventive action and a fire occurs, the tool will send a fire warning message to the fire department accompanied by the fire location point via Telegram message so that the reception of fire location information by the fire department can be faster because the location point sent is a coordinate and also Google Maps navigation links.

In the previous research mentioned previously, the research carried out could only detect gas leaks or fires and provide danger notification to only 1 user, namely the building owner, therefore in this research the author carried out developments in the form of additional detection of the presence of smoke and also high temperatures. usually there is when a fire occurs and also additional detection of the location of the fire which will be sent in the form of coordinates and also Google Maps navigation link to users other than the building owner, namely the local fire department so that the local fire department can find the location of the fire more easily because it will be navigated directly by Google Maps.

In this research, an ESP32 microcontroller is used which can be connected to the internet [10] so that the tools in this research can later be connected to the internet as well so that it becomes a system. *Internet of Things* (IoT) [11], then the MQ-6 sensor is used to detect the presence of LPG gas [12], the IR fire sensor is used to detect the presence of fire [13], the MQ-2 sensor is used to detect the presence of smoke which can appear when a fire occurs [14], then the DHT22 temperature sensor will be used to read the temperature of the building where high temperatures are one of the things that will happen if a fire occurs [15]. Finally, to find out the location of the point where the fire occurred, this research tool uses the Neo-6M GPS module to read the coordinates of the location where it occurred. fire [16].

Furthermore, for sending danger warning messages and fire location coordinates, the Telegram messaging application is used, although the use of other messaging applications such as Whatsapp is higher, namely around 60% of messaging application usage. *online* in the world, Telegram has several features that are better than Whatsapp, such as in terms of synchronization, speed, backup, and security [17] and another reason Telegram is used in this research is the Bot Father feature found in Telegrams so that in this research a Bot account as the identity of the research tool on Telegram to be able to send messages

to users, namely building owners and also firefighters [18].

It is hoped that with this research, fires caused by LPG gas leaks can be prevented and if a fire occurs, this tool can quickly notify the fire department of the location of the fire so that the fire department can anticipate the occurrence of a fire more quickly.

## II. METHOD

### A. System Overview

To make it easier to understand how this research tool works, the author has made a general description of the tool system created in this research. A general description of this research tool can be seen in the image below:

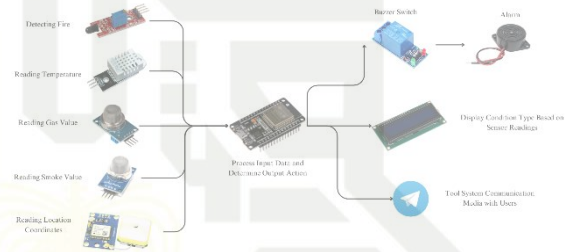

Figure 1. Overview of the Gas Leak and Fire Detection System

As shown in Figure 1, in this research tool system there are 5 components for input data, namely the Infrared Flame Sensor, the DHT22 Temperature Sensor, MQ-6 Gas Sensor, MQ-2 Smoke Sensor, and Neo-6M GPS Module. Then there is the ESP32 as a microcontroller which processes the input data which will later influence the output of the system, namely the Relay Module, Buzzer, LCD, and also Telegram messages.

This research tool will use the MQ-6 sensor to detect gas leaks, where if a gas leak is detected which is indicated by high levels of butane contained in LPG gas, the ESP32 will order the relay module to turn on a danger alarm in the form of a buzzer, then display a status message. danger in the form of a gas leak on the LCD screen, and sending the same message to the user's cellphone via Telegram Messenger.

Likewise with fire detection, if at a location there are 4 fire criteria used in this research, namely Fire, Gas, Smoke, and High Temperature, the ESP32 will order the relay to turn on the buzzer as an alarm, display a fire danger message on the LCD, and send a message. danger of fire to users where the user in question is the building owner and also the local fire department via the Telegram messaging application, apart from fire messages the user will also receive the coordinates of the fire which is found by the Neo-6M GPS Module where the coordinates of the fire are known This means that the fire department has the possibility of finding the location of the fire more quickly.



**B. Hardware Design**

As explained in the system overview section, this research uses several electronic components in the system, therefore it is necessary to design hardware for these components so that they can be integrated with each other to work to achieve the desired function. For the hardware design of this research, it can be seen in the image below. :

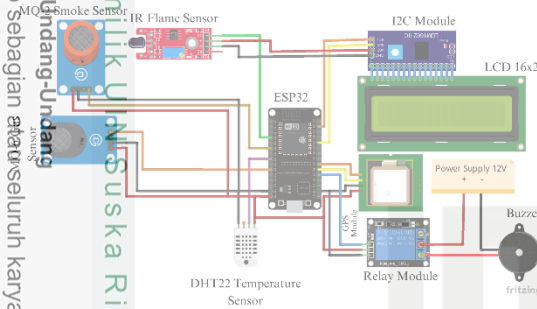

Figure 2. Schematic of the Gas Leak and Fire Detection System Circuit

It can be seen in Figure 2 that in the gas leak and fire detection system, the components used are all connected into one unit where ESP32 is the center of the gas leak and fire detection system. To find out more clearly the relationship between components in the schematic of the system circuit above, the following is a table of the relationships between them. Components that show connectivity between components in this research tool system:

Table 1. Connectivity between system components

Component Pin	Connection Pin
IR Flame Sensor Pin	ESP32 Pin 34
MQ-6 Gas Sensor Pin	ESP32 Pin 35
MQ-2 Smoke Sensor Pin	ESP32 Pin 33
DHT22 Temperature Sensor Pin	ESP32 Pin 25
GPS Module RX Pin	ESP32 Pin 17
GPS Module TX Pin	ESP32 Pin 16
Relay Module In Pin	ESP32 Pin 4
SDA Pin of I2C LCD	ESP32 Pin 21
SCL Pin of I2C LCD	ESP32 Pin 22
Buzzer	NO of Relay Module

**C. Software Design**

Programming is required on the ESP32 so that the entire system can work according to the desired function, therefore the following is a flowchart that explains the work flow of the system which will later be written in program form into the ESP32:

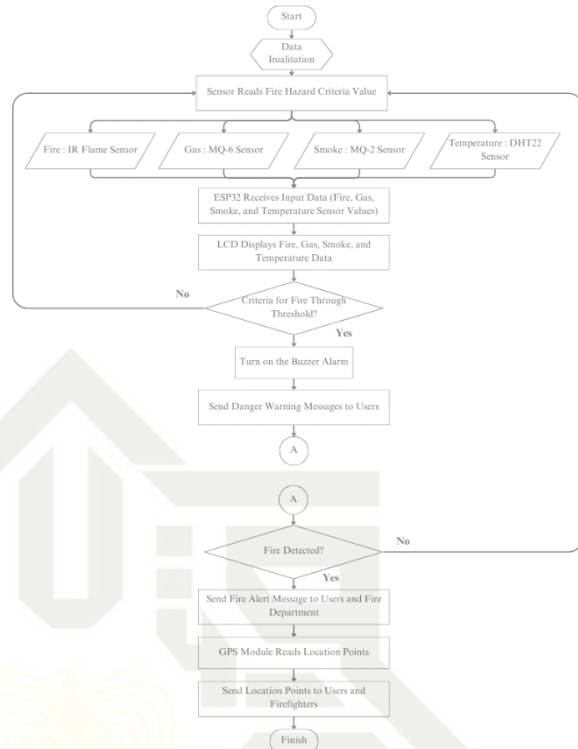

Figure 3. Flowchart Gas Leak and Fire Detection System

Figure 3 explains the system process of the gas leak and fire detection device. The sensor will detect the criteria for fire and gas leaks in the form of the presence of fire, the presence of smoke, the presence of gas, and also the presence of high temperatures. Some of the criteria mentioned have threshold values that have been programmed into the ESP32 so that if the sensor reaches a reading up to the threshold value then the existence of the criteria will be deemed to exist.

For the fire sensor, because the output used is a digital output, therefore, when a HIGH output is detected from the sensor, the presence of a fire will be deemed to exist by the ESP32. For the threshold for LPG gas, 100 PPM is used as the limit, which is as stated by *Occupational Safety and Health Administration (OSHA)* states that the maximum limit for exposure to LPG gas is 125 PPM for a period of 1 hour, therefore values above 100 PPM for a shorter time are marked as dangerous conditions [19].

Then the threshold used for smoke levels is 100 PPM because according to *National Institute for Occupational Safety and Health (NIOSH)* normal limit for smoke dioxide levels that can be exposed to closed rooms is 200 PPM for 15 minutes, therefore for a shorter time 100 PPM is marked as an abnormal condition and is also dangerous if exposed to humans [20], and for The high temperature included in the fire criteria in this study is a temperature above 35°C because temperatures above this temperature are categorized as abnormal [21].

If the sensor has detected the presence of the fire or gas leak criteria, the ESP32 will turn on the buzzer alarm and will display a danger message on the LCD then the danger message will also be sent to the user's Telegram and if a fire is detected, namely when all the





criteria are met, the coordinates of the fire location will also be sent to firefighter

**2. Cool Testing**

At this stage, tests will be carried out on the tools that have been made in this research, where the tests carried out are testing the accuracy of temperature readings, testing the detection of the presence of fire, testing the presence of smoke, and also the presence of

Apart from testing the sensors on the tool, the tool's ability to send danger messages to users via telegram will also be tested along with the tool's ability to send coordinates of the location of the tool where the coordinates sent will later be compared with the original location to determine the accuracy of the location reading by the tool.

After testing the functionality of the tool, accuracy testing between real conditions and the conditions found by the tool will also be tested to determine whether this tool works correctly and the results match the real conditions that occur.

**III. RESULTS AND DISCUSSION**

**A. Functionality Testing**

**1. Testing for the Presence of Fire**

This test was carried out to determine the ability of the IR fire sensor to detect fire. This test was carried out by gradually bringing a lighter that was turned on from further away until it was closer to the sensor. The distance in this test was carried out at a distance of 15, 10 and 5 cm. The following is test results from the fire sensor:

Table 2. Flame Sensor Test Results

Distance	Api	Buzzer	Telegram Messages	Location Point
15 cm	Not detected	Not active	Not sent	Not sent
10 cm	Detected	Active	Sent	Sent
5 cm	Detected	Active	Sent	Sent

The table above shows that the fire sensor can detect the presence of fire from 10 cm down and when fire is detected, the device will sound a buzzer as an indication of danger accompanied by sending a danger message to the user via telegram. Because the distance where the fire was detected was very close, namely less than 10 cm, the presence of this fire in this study was categorized as a possible fire.

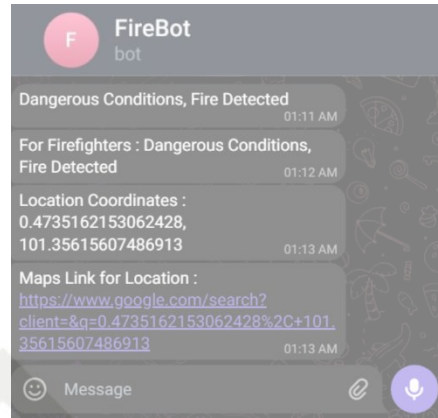

Figure 4. Fire Warning Message

It can be seen in Figure 4, when a fire is detected, the tool will send a fire warning message to the user, building owner and also the local fire department, accompanied by a location point and also a link to go to the location of the fire, where the location point and this link can show a map of the location where it occurred. fire using Google Maps.

**2. Gas Presence Testing**

This test was carried out to determine the ability of the MQ-6 gas sensor to detect the presence of gas or gas leaks that occur around the sensor in accordance with a predetermined threshold of 100 PPM. This test was carried out by bringing the lighter gas closer gradually starting from 15 cm up to 5 cm, the following are the results of tests carried out on the MQ-6 gas sensor:

Table 3. Gas Presence Test Results

Distance	PPM	Gas Concentration	Buzzer	Telegram Messages
15 cm	4.2	0.00042%	Not active	Not sent
10 cm	93.8	0.00938%	Not active	Not sent
5 cm	112.6	0.01126%	Active	Sent

From the table above, it is known that the closer the distance of the gas from the lighter, the PPM value of the gas read by the sensor will increase as well as the concentration level of LPG gas and when the PPM value read by the sensor exceeds the specified threshold value, namely 100 PPM, then the buzzer The device will sound, indicating danger.

2. Dilarang mengemukakan dan memperbanyak sebagian atau seluruh karya tulis ini dalam bentuk apapun tanpa izin UIN Suska Riau.

a. Pengutipan hanya untuk kepentingan pendidikan, penelitian, penulisan karya ilmiah, penyusunan laporan, penulisan kritik atau tinjauan satu masalah.

b. Pengutipan tidak merugikan kepentingan yang wajar UIN Suska Riau.

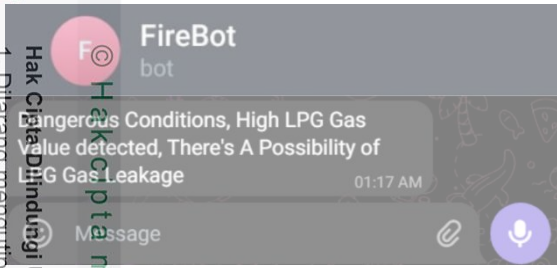

Figure 5. Gas Leak Warning Message

Figure 5 is a display of the message received by the user when a gas leak is detected in the Telegram messaging application, where this message will be received by the user if the system detects the presence of LPG gas with an amount exceeding 100 PPM.

**3. Testing for the presence of smoke**

This test was carried out to determine the ability of the MQ-2 smoke sensor to detect the presence of smoke in the room occupied by the device. This test is the same as testing on fire and gas, the source of smoke will be gradually brought closer to the smoke sensor on the device starting from 15 cm to 5 cm where the source of smoke in this test is burning paper. The following is a table of test results for the presence of smoke on the MQ-2 sensor:

Table 4. Test results for the presence of smoke

Distance	PPM	Smoke Concentration	Buzzer	Telegram Messages
15 cm	2.8	0.00028%	Not active	Not sent
10 cm	76.1	0.00761%	Not active	Not sent
5 cm	103.7	0.01037%	Active	Sent

From the tests carried out, it is known that the tool detects the presence of smoke that exceeds the PPM threshold value for the presence of smoke, namely 100 PPM, when smoke enters a distance of 5 cm from the smoke sensor and from the table it is known that the closer the smoke is, the PPM value and carbon dioxide concentration in the smoke will also increase, when the presence of smoke the PPM value reaches or exceeds the threshold value, the buzzer will turn on to indicate danger.

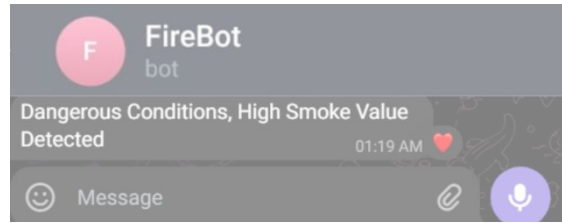

Figure 6. High Smoke Rate Warning Message

Figure 6 shows the message that the user will receive when smoke is detected that exceeds the specified normal threshold, namely 100 PPM, which indicates that the condition of the room occupied by the device is no longer safe.

**4. DHT22 Temperature Sensor Testing**

This test was carried out to determine the accuracy of the temperature reading by the DHT22 temperature sensor with the original temperature read by the digital room thermometer. This test was carried out by comparing the temperature readings of the two devices for 3 hours every 30 minutes. The following are the test results from the temperature sensor:

Table 4. Test results for the presence of smoke

Time	Measurement results		Difference	Buzzer	Telegram Messages
	DHT 22	Thermometer			
12.00	34	34	0	Not active	Not sent
12.30	35	34	1	Active	Sent
13.00	35	35	0	Active	Sent
13.30	33	32	1	Not active	Not sent
14.00	33	32	1	Not active	Not sent
14.30	31	31	0	Not active	Not sent
15.00	31	30	1	Not active	Not sent

From the table above it is known that the DHT22 sensor can have a difference of 1 degree in the temperature reading with the original room temperature reading using a room thermometer which has a difference of 1 degree. and when the sensor detects that the room temperature exceeds the specified threshold, namely 35 degrees, the buzzer will sound.

2. Dilarang mengemukakan dan memperbanyak sebagian atau seluruh karya tulis ini dalam bentuk apapun tanpa izin UIN Suska Riau.

1. Dilarang mengutip sebagian atau seluruh karya tulis ini untuk tujuan komersial atau untuk menyalahgunakan hak cipta milik Universitas Islam Sumatera Utara.

a. Pengutipan hanya untuk kepentingan pendidikan, penelitian, penulisan karya ilmiah, penyusunan laporan, penulisan kritik atau tinjauan suatu masalah.

b. Pengutipan tidak merugikan kepentingan yang wajar UIN Suska Riau.

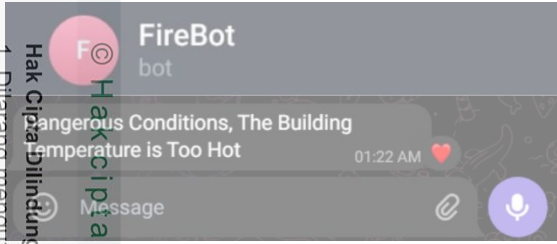

Figure 7. High Temperature Warning Message

As shown in Figure 7, a high temperature warning message will also be sent to the user when the system detects the presence of a high temperature that exceeds the threshold of 55 degrees Celsius during operation.

5. Neo-6M GPS Module Testing

This test was carried out to determine the accuracy of the location readings read by the Neo-6M GPS module on the resulting device. This test was carried out by comparing the Neo-6M GPS module readings with GPS readings on a smartphone where the comparison was carried out using the Google Maps application. The following are the test results from the GPS module:

Table 5. Coordinates of Test Results

Latitude		Longitude	
Neo-6M	Google Maps	Neo-6M	Google Maps
0.4735162	0.4735483	101.35615	101.35596
153062428	357722569	607486913	385423133

From the test results table above, it can be seen that the reading results between the Neo-6M GPS module and Google Map have a slight difference, this distance difference can also be measured via Google Maps, the following is a location comparison image between the exact location by Google Maps and the location of the GPS module reading results Neo-6M :

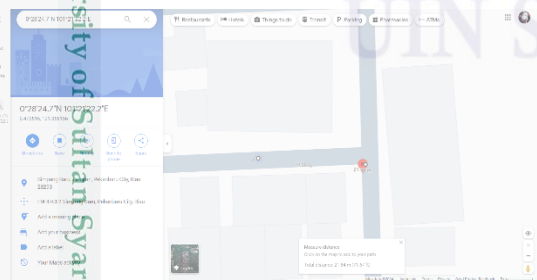

Figure 8. Comparison of location readings using Google Maps

From Figure 8 it is known that the results of reading the GPS module with Google Maps have a slight difference where there is a distance of 21.84 m between the exact location shown by Google Maps and the location shown by the Neo-6M GPS module.

6. Real Time Condition Comparison Testing

Testing This test is carried out to determine whether the conditions found by the tool and sent to the user match the conditions that actually occur, and in this test the response time of the tool is also measured in responding to surrounding conditions in sending messages regarding conditions to the user via telegram:

Table 5. Coordinates of Test Results

Telegram Messages	Real Conditions	Tool Response Speed	Message Delivery Speed	Messages According to Real Conditions
Dangerous Conditions, Fire Detected	Fire Source (Match) Turned On At A Distance $\leq 10$ cm	1.18 Sec	1.52 Sec	✓
	Dangerous Condition, Possible Gas Leak	1.23 Sec	2.09 Sec	✓
Dangerous Conditions, High Smoke Levels	Bring lighter gas closer to the tool at a distance of $\leq 5$ cm	0.89 Sec	3.31 Sec	✓
	The smoke source (burning paper) is brought closer to the tool at a distance			

2. Dilarang mengumumkan dan memperbanyak sebagian atau seluruh karya tulis ini dalam bentuk apapun tanpa izin UIN Suska Riau.

1. Dilarang mengutip sebagian atau seluruh karya tulis ini tanpa izin UIN Suska Riau.

a. Pengutipan hanya untuk kepentingan pendidikan, penelitian, penulisan karya ilmiah, penyusunan laporan, penulisan kritik atau tinjauan suatu masalah.

b. Pengutipan tidak merugikan kepentingan yang wajar UIN Suska Riau.



2. Dilarang mengemukakan dan memperbanyak sebagian atau seluruh karya tulis ini dalam bentuk apapun tanpa izin UIN Suska Riau.

1. Dilarang mengutip sebagian atau seluruh karya tulis ini tanpa mengemukakan sumber.

a. Pengutipan hanya untuk kepentingan pendidikan, penelitian, penulisan karya ilmiah, penyusunan laporan, penulisan kritik atau tinjauan satu masalah.

b. Pengutipan tidak merugikan kepentingan yang wajar UIN Suska Riau.

ce of			
≤5 cm			
Fire source (candle) is placed near the tool for 10 minutes	1.19 Sec	2.13 Sec	✓

From the experiments carried out on the tool, it is known that the response results from the tool are in accordance with the real conditions that occur near the tool, where each experiment per fire criterion has a different response time. The response time in question is the time the tool responds to dangerous conditions when a fire criterion is detected. From the experiments carried out, it is known that the tool has an average response time of 1.12 seconds and the average time for sending warning messages is 2.26 seconds.

IV. CONCLUSION

From the research that has been carried out, the author can conclude that the tool produced in this research is successful in detecting the presence of gas leaks and fires and when these two conditions are detected the tool is successful in sending warning messages according to real conditions that occur via the telegram messaging application and if a fire occurs when the tool also succeeded in sending the coordinates of the location of the fire along with the danger warning message sent.

V. BIBLIOGRAPHY

[1] V. Hafistianti, M. A. W. Linggasani, S. Natali, and D. Hartabela, "Fire Risk Protection in Housing. Case Study of New Housing in Cigadung Subdistrict, Bandung," ZONASI Architectural Journal, vol. 2, no. 1, p. 1, Feb. 2019, doi: <https://doi.org/10.17509/jaz.v2i1.15061>.

[2] M. Hafiz and O. Candra, "Design of a Microcontroller-Based Fire Detection System and Map Application Using IoT," JTEV (Journal of Electrical and Vocational Engineering), vol. 7, no. 1, p. 53, March. 2021, doi: <https://doi.org/10.24036/jtev.v7i1.111420>.

[3] D. Novianti and C. Chairil, "Analysis of Fire Protection Systems in Densely Populationd Areas (Case Study in Kertapati Subdistrict, Palembang)," TEKNIKA: Engineering Journal, vol. 5, no. 2, pp. 117–129, Jan. 2019, doi: <https://doi.org/10.35449/teknika.v5i2.97>.

[4] A. Cahyadi, F. Lestari, and A. Kadir, "Analysis of Fire Disaster Risk Levels in the West Jakarta Region, DKI Jakarta Province," PREPOTIF Journal of Public Health, vol. 6, no. 1, pp. 468–477, Apr. 2022..

[5] G. Indra, Putu Adhitya Santika Dharma, A. Putra, and I. Bagus, "Early Gas Leak and Fire Detection Using Telegram-

Based NodeMCU," Electrical Technology Scientific Magazine, vol. 21, no. 1, pp. 13–13, Jul. 2022, doi: <https://doi.org/10.24843/mitte.2022.v21i01.p03>.

[6] R. Inggi and J. Pangala, "Design of an LPG Gas Leak Detection Device Using an Arduino-Based MQ-2 Sensor," SIMKOM, vol. 6, no. 1, pp. 12–22, Jan. 2021, doi: <https://doi.org/10.51717/simkom.v6i1.51>.

[7] M. Wahidin, A. Elanda, and S. Lie, "Implementation of a Fire Detection System Based on IoT and Telegram," Intercom Journal: Journal of Scientific Publications in the Field of Information and Communication Technology, vol. 16, no. 2, Aug. 2021, doi: <https://doi.org/10.35969/interkom.v16i2>.

[8] A. Saputra, J. Maulindar, and R. Susanto, "Design and Development of the Benefits of the Internet of Things for Detecting Gas Leaks," Infotech Journal, vol. 9, no. 1, pp. 223–231, May 2023, doi: <https://doi.org/10.31949/infotech.v9i1.2023>.

[9] F. Amir, Novianda Novianda, and Rahmat Maulana, "Liquefied Petroleum Gas Leak Detection System Using the Fuzzy Logic Mamdani Method Based on the Internet of Things," Journal of Technology, Muhammadiyah University, Jakarta, vol. 12, no. 2, pp. 151–158, Jul. 2020, doi: <https://doi.org/10.24853/jurtek.12.2.151-158>.

[10] L.-R. Carlos, Z.-R. V. Manuel, O. Noelia, and M.-L. Gerardo, "Wireless Sensor Networks Applications for Monitoring Environmental Variables Using Evolutionary Algorithms," Jan. 2018, doi: <https://doi.org/10.1016/b978-0-12-812130-6.00014-7>.

[11] T. Lynn, P. T. Endo, A. M. N. C. Ribeiro, G. B. N. Barbosa, and P. Rosati, "The Internet of Things: Definitions, Key Concepts, and Reference Architectures," The Cloud-to-Thing Continuum, pp. 1–22, 2020, doi: [https://doi.org/10.1007/978-3-030-41110-7\\_1](https://doi.org/10.1007/978-3-030-41110-7_1).

[12] A. Sujiwa and H. P. Prasetyo, "Measurements Analysis of MQ-6 LPG Gas Leak Detection Devices for Distance Factors," BEST : Journal of Applied Electrical, Science, & Technology, vol. 2, no. 1, pp. 6–9, Aug. 2020, doi: <https://doi.org/10.36456/best.vol2.no1.2578>.

[13] H. Bordbar, F. Alinejad, K. Conley, T. Ala-Nissila, and S. Hostikka, "Flame detection by heat from the infrared spectrum: Optimization and sensitivity analysis," Fire Safety Journal, vol. 133, p. 103673, Oct. 2022, doi: <https://doi.org/10.1016/j.firesaf.2022.103673>.

[14] Sabar, J. Joni, Kisna Pertiwi, Ratih Rundri Utami, and Sastra, "Design Virtual Instrumentation System of a Cigarette Smoke Detector," Formosa Journal of Sustainable Research, vol. 2, no. 3, pp. 555–564, March. 2023, doi: <https://doi.org/10.55927/fjsr.v2i3.3502>.

[15] W. Adhiwibowo, A. F. Daru, and A. M. Hirzan, "Temperature and Humidity Monitoring Using DHT22 Sensor and Cayenne API," Jurnal Transformatika, vol. 17, no. 2, p. 209, Jan. 2020, doi: <https://doi.org/10.26623/transformatika.v17i2.1820..>

[16] S. H. Bujang, H. Suhaimi, and P. E. Abas, "Performance of low cost Global Positioning System (GPS) module in location tracking device," IOP Conference Series: Materials Science and Engineering, vol. 991, p. 012137, Dec. 2020, doi: <https://doi.org/10.1088/1757-899x/991/1/012137>.

[17] A. Shahrul and A. P. Wibawa, "Choosing an Instant Messaging App: Security or Convenience? Comparison



between Whatsapp and Telegram,” Buletin Ilmiah Sarjana Teknik Elektro, vol. 3, no. 2, pp. 115–121, Sep. 2021, doi: <https://doi.org/10.12928/biste.v3i2.2784>.

8] A. D. Mulyanto, "Utilization of Telegram Bots for Research Information Media," MATICS, vol. 12, no. 1, p. 49, Apr. 2020, doi: <https://doi.org/10.18860/mat.v12i1.8847>.

9] T. N. Arifin, G. F. Pratiwi, and A. Janrafsasih, "ELPIJI Gas Leak Detection Tool," Tera Journal, vol. 2, no. 1, pp. 26–33, March, 2022..

10] S. F. Prastyana and S. A. M. Uktutias, "Risk Assessment of Exposure to Carbon Monoxide in a Residential Area around Tofu Manufacturing ,” Jurnal Kesehatan Lingkungan, vol. 13, no. 2, pp. 57–63, Apr. 2021, doi: <https://doi.org/10.20473/jkl.v13i2.2021.57-63..>

11] M. Fachmi, M. Saepudin, and I. Rossa, "The Relationship Between Work Climate and Workforce Fatigue at Pt. Shinam Jaya Abadi, Wajokhulu Village, Mempawah Regency," Borneo Akcaya Journal, vol. 6, no. 1, pp. 89–92, Jun. 2020.

**Hak Cipta Dilindungi Undang-Undang**

1. Dilarang mengutip sebagian atau seluruh karya tulis ini tanpa mencantumkan dan menyebutkan sumber:

- a. Pengutipan hanya untuk kepentingan pendidikan, penelitian, penulisan karya ilmiah, penyusunan laporan, penulisan kritik atau tinjauan suatu masalah.
- b. Pengutipan tidak merugikan kepentingan yang wajar UIN Suska Riau.

2. Dilarang mengumumkan dan memperbanyak sebagian atau seluruh karya tulis ini dalam bentuk apapun tanpa izin UIN Suska Riau.





Ternate, 20 April 2024

Submission Id : 7744  
 Letter of Acceptance

Dear

Nanda Wibowo, Hilman Zarory, Dian Mursyitah, Aulia Ullah:

We have reached a decision regarding your submission to PROtek : Jurnal Ilmiah Teknik Elektro, "Fire Detection Design Based on Gas Leakage Accompanied by Fire Location Point Using ESP32 Based on IoT".

**Our decision is to: Accept Submission**

Based on the review results, the article will be published in PROtek : Jurnal Ilmiah Teknik Elektro. Volume 12 Nomor 1 January 2025. The article is available online at <http://ejournal.unkhair.ac.id/index.php/protek>

This information is conveyed, and for your attention, thank you

Editor In Chief



Dr. Iis Hamsir Ayub Wahab, M.Eng., IPU

State Islamic University of Sultan Syarif Kasim Riau

Hak Cipta Diindungi Undang-Undang  
 1. Dilarang mengutip sebagian atau seluruh karya tulis ini tanpa mencantumkan dan menyebutkan sumber:  
 a. Pengutipan hanya untuk kepentingan pendidikan, penelitian, penulisan karya ilmiah, penyusunan laporan, penulisan kritik atau tinjauan suatu masalah.  
 b. Pengutipan tidak merugikan kepentingan yang wajar UIN Suska Riau.  
 2. Dilarang mengumumkan dan memperbanyak sebagian atau seluruh karya tulis ini dalam bentuk apapun tanpa izin UIN Suska Riau.

INDEXED IN

