

Cutting Technique for Constructing Small Radial Line Slot Array (RLSA) Antennas

Teddy Purnamirza¹, Muhammad I. Ibrahim², Rika Susanti³, Sutoyo⁴, Mulyono⁵, Hasdi Radiles⁶, Depriwana Rahmi⁷

Abstract

The design of small Radial Line Slot Array (RLSA) antennas requires more than simply decreasing the antenna radius. This is because of the problem of high reflection. To overcome this problem, we introduce a cutting technique for constructing small RLSA antennas with low reflection. Rather than decreasing the radius as usual, the cutting technique generates small RLSAs by cutting full-sized RLSAs. We designed 42 ordinary full-sized RLSA models with a radius of 75 mm and then cut them into 42 half RLSAs and 42 quarter RLSAs. The half RLSAs and the quarter RLSAs are equal in size to a full-sized RLSA, with radii of 53 mm and 37 mm, respectively. The results show that the gain of the quarter RLSA decreases only 1 dB compared to the full RLSAs, whereas theoretically its gain should decrease 6 dB due to the size reduction. Interestingly, the gain of the half RLSAs increases 1 dB compared to full RLSAs, whereas it should theoretically decrease 3 dB due to the size reduction. The half RLSA and the quarter RLSA also perform good performance in term of reflection coefficient and bandwidth, thus verify the potency of the cutting technique in constructing small low reflection RLSAs.

Key Words: small RLSA antennas, cutting technique, quarter RLSA, half RLSA

I. INTRODUCTION

Radial line slot array (RLSA) antennas have received considerable attention since 1985 [1]. Originally, researchers developed RLSA antennas as high-gain antennas with a diameter of no less than 600 mm to be used as receiver antennas for satellite communications [2–8]. Due to the advantages of RLSA antennas, such as high gain and high efficiency [3, 5, 9], researchers have focused on the design of smaller RLSA antennas

with a diameter of less than 150 mm for smaller antenna applications, such as millimeter waves [10–12], mobile satellites [13], and wireless local area networks [14–16].

However, the development of small RLSA antennas has encountered the problem of high reflection coefficients for years, which is due to an insufficient number of their slots [2, 17]. Several research studies have proposed techniques to overcome this problem [2, 17–21]; among them, the extreme beamsquint

Manuscript received June 02, 2020 ; Revised July 27 2020 ; Accepted September 09, 2020. (ID JEES-2020-0143.R1)

^{1,3,4,5,6} Department of Electrical Engineering, Faculty of Science and Technology, Universitas Islam Negeri Sultan Syarif Kasim Riau, Riau, Indonesia.

² Faculty of Electrical Engineering, Universiti Teknikal Malaysia, Malaka, Malaysia

⁷ Department of Mathematic Education, Faculty of Education and Teacher Training, Universitas Islam Negeri Sultan Syarif Kasim Riau, Riau, Indonesia

Corresponding Author: Teddy Purnamirza (email: tptambusai@uin-suska.ac.id)

This is an Open-Access article distributed under the terms of the Creative Commons Attribution Non-Commercial License (<http://creativecommons.org/licenses/by-nc/3.0>) which permits unrestricted non-commercial use, distribution, and reproduction in any medium, provided the original work is properly cited.

technique is the most attractive [17]. Using this technique, small RLSA antennas with a radius of 75 mm and at a frequency of 5.8 GHz could be designed without high reflection coefficients, which other techniques could not achieve previously. Several studies have also reported this technique's success in the development of small low-reflection antennas for Wi-Fi market needs [22–26].

To further design small RLSA antennas with a radius less than 75 mm, we cannot simply reduce the antenna radius or use the extreme beamsquint technique directly. This is because reducing the antenna radius will significantly decrease the number of slots, which will then increase the reflection coefficient (see the illustration in Fig. 1). Fig. 1(a) shows a small RLSA antenna with a radius of 75 mm, three rings and nineteen slot pairs. This antenna has a good reflection coefficient (dotted line curve), as shown in Fig. 1(c). When we reduce the antenna size by decreasing its radius to 48 mm, there is only one ring, and the number of slot pairs is significantly reduced to six, as shown in Fig. 1(b). This small number of slot pairs of the antenna in Fig. 1(b) would not be able to radiate all of the power from its feeder, so some remaining power would remain at the antenna's perimeter. This remaining power will be reflected back to the feeder and increase the reflection coefficient. Fig. 1(c) shows the high reflection coefficient (solid line curve) of the antenna from Fig. 1(b).

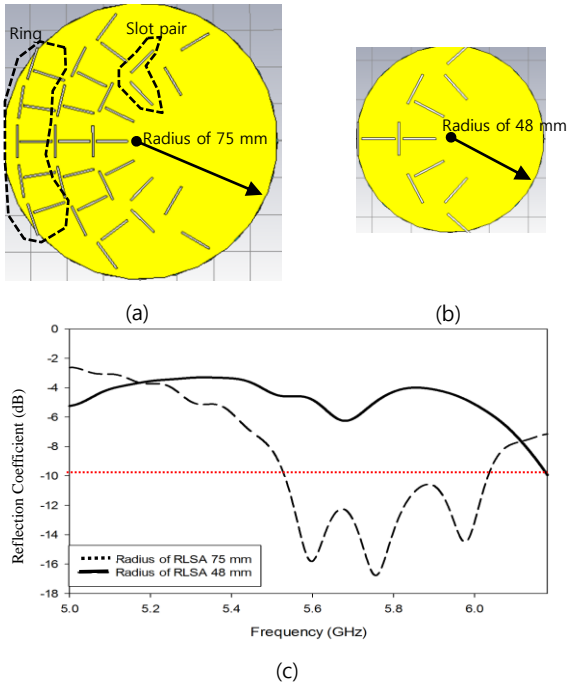

Fig. 1. (a) RLSA antenna with radius of 75 mm (b) RLSA antenna with radius of 48 mm (c) Reflection coefficient of both RLSAs

As explained in the previous paragraph, decreasing the radius is not useful for developing small RLSA antennas, especially a radius less than 75 mm. Therefore, we introduce a new technique of cutting RLSA antennas, aiming to generate small low-reflection antennas. Using this technique, rather than reducing the antennas radius, ordinary RLSA antennas are cut to obtain small RLSA antennas. This is an unusual approach, as cutting results in the RLSA antennas no longer having the form of a full circle. Moreover, although such cutting could result in small low-reflection RLSAs, it may affect the gain due to power leakage along the cutting line.

In this paper, we first discuss the cutting technique and its effect in detail in Section II. In Section III, we report on the design and simulation of several antenna models with a radius of 75 mm, which are cut into halves and quarters. We also fabricate and measure the prototypes. In order to verify the cutting technique, in Section IV, we analyze and compare the simulation and measurement results in terms of reflection coefficient, bandwidth and gain. Finally, in Section V, we conclude the analysis and suggest future researches.

II. THE CUTTING TECHNIQUE AND ITS EFFECTS

RLSA antenna slots are normally distributed uniformly on the entire surface of the antenna, as shown in Fig. 2(a). In order to have low reflection, a sufficient number of slots is required to radiate power. Therefore, the slots must be as close together as possible. We used high beamsquint values to design adjacent slots. The result of the design is a concentrated slot area and a vacant area, as shown in Fig. 2(b). The vacant area should not contribute to the antenna gain since it has no slots to radiate power. We hypothesized that we might cut and remove the vacant area to produce a smaller antenna. Fig. 2(c) and (d) depict two smaller antennas resulting from these cuts.

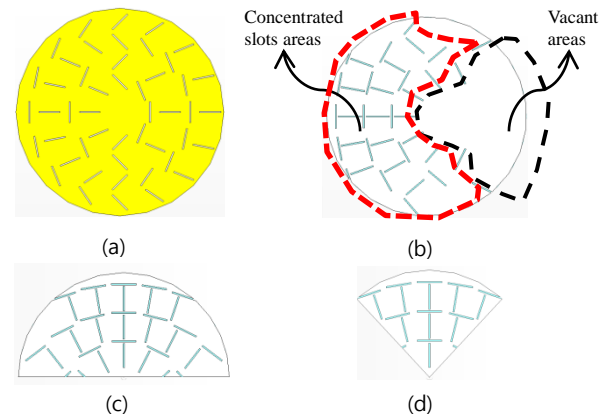

Fig. 2. (a) RLSA antenna (b) RLSA antenna designed using a high beamsquint value (c) cut in half and (d) cut in a quarter

We further hypothesized that the cut RLSAs in Fig. 2(c) and (d) would have a power density inside the antenna cavity higher than that of the full RLSA in Fig. 2(b). The power density is about two times more in the half RLSA and about four times more in the quarter RLSA than in the full RLSA. Logically, these increases occur because the perimeter area of the quarter and half RLSAs are two times and four times smaller than that of the full RLSA, respectively. Fig. 3 illustrates the perimeter area of RLSA antennas. From this figure, we observe that the power density of the full RLSA, the quarter RLSA and the half RLSA are $P/2\pi Rh$, $P/2\pi Rh/4$, and $P/2\pi Rh/2$, respectively.

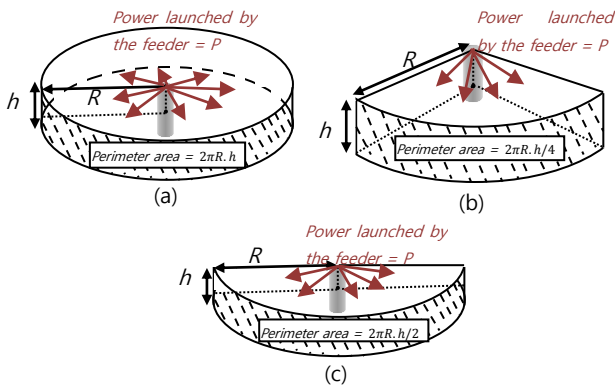

Fig. 3. Perimeter area of (a) Full RLSA (b) quarter RLSA (c) half RLSA

The higher power density should lessen the reflection coefficients, widen the bandwidth, and increase the gain, as more power will escape from these RLSAs' slots compared to those of the full RLSA. Hence, less remaining power at the antenna's perimeter will be reflected back to the feeder compared to the full RLSA, thereby reducing the reflection coefficients.

A negative effect of cutting is power leakage along the cutting edge, as indicated by the simulation depicted in Fig. 4(a) and (b). The power leakage might reduce the gain since the power escapes from the antenna without going through the slots, thus interfering with the gain's focus. However, the effect of higher power density in the half and quarter RLSAs might compensate for the gain reductions due to the power leakage.

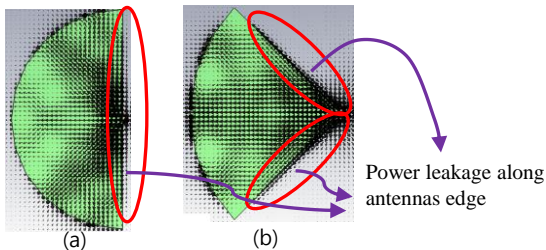

Fig. 4. (a) Power leakage in the half RLSA; (b) power leakage in the quarter RLSA.[26]

III. ANTENNA MODELS AND PROTOTYPES

We designed and simulated about 42 RLSA antenna models using high beamsquint values. All these models differed in terms of their beamsquint values (θ) and the number of slots in the first ring (p_0). We used different θ and p_0 in order to ensure that the cutting technique is applicable for different values of θ and p_0 . Furthermore, we cut each of the 42 models into 42 half RLSAs and 42 quarter RLSAs and simulated them to analyse the cutting effect. Fig. 5 depicts a sample of the models both before and after they were cut as well as their feeder.

The antenna in Fig. 5(a) has an area of $\pi \times r^2 = \pi \times 7.5 \text{ cm}^2 = 176.6 \text{ cm}^2$, while the half antenna in Fig. 5(b) and the quarter antenna in Fig. 5(c) have an area of half of 176.6 cm^2 and one-quarter of 176.6 cm^2 , or 88.3 cm^2 and 44.15 cm^2 , respectively. This means the half antenna and the quarter antenna have an area equal to a full antenna, with radii of 53 mm and 37 mm , respectively.

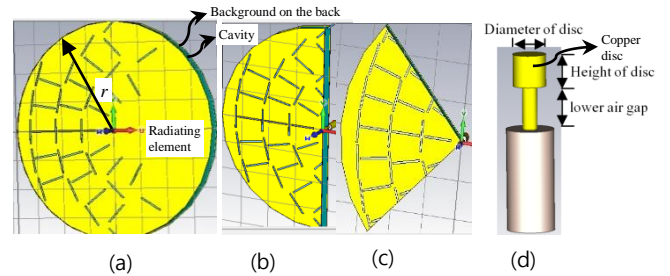

Fig. 5. A model of the (a) full RLSA, (b) half RLSA, (c) quarter RLSA, and (d) feeder [17-18].

The models' structure consists of a radiating element (made of copper) at the top, a cavity (made of polypropylene) in the middle, a background (made of copper) on the back and a feeder in the center. The feeder is an ordinary Sub-Miniature version A (SMA) feeder that we modified by adding a copper disc, as illustrated in Fig. 5(d). The copper disc is useful for modifying transverse electromagnetic mode (TEM) coaxial mode signals into TEM cavity mode signals so that the signals fed by the feeder will propagate in a radial direction within the antenna cavity.

The difficulty in drawing the antenna structure manually, especially the slots, led to the development of a computer program to draw the models' structures faster and more accurately. All the design parameters embedded in the computer program are listed in Tables 1, for the antenna and the feeder, while Figs. 5(a) and (d) depict their respective definitions.

Tabel 1. Specification Parameters of the Antenna Models and Feeder [17-18]

Symbol	Parameter	Value
f	frequency	5.8 GHz
r	antenna radius	75 mm
n	number of slot pairs in first ring	10, 12, 14, 16
θ	beamsquint angle	75° up to 89°
d_1	cavity thickness	8 mm
d_2	radiating element thickness	0.1 mm
d	background thickness	0.1 mm
ϵ_{r1}	cavity permittivity	2.33
h	disc height	3 mm
r_a	disc radius	1.4 mm
b_1	lower air gap	4 mm
b_2	upper air gap	1 mm

Several equations were used in the computer program to calculate the inclination angle of the slots' pairs (Eq.1 and Eq.2), their positions (Eq.3 and Eq.4), the distance between them (Eq.5 and Eq.6), and their length (Eq.7) [1-3]. Table 2 lists the definitions of the slots pairs' parameters in all the equations while Fig. 6 was used to explain them.

$$\theta_1 = \frac{\pi}{4} + \frac{1}{2} \left\{ \arctan \left(\frac{\cos(\theta_T)}{\tan(\phi_T)} \right) - (\phi - \phi_T) \right\} \quad (1)$$

$$\theta_2 = \frac{3\pi}{4} + \frac{1}{2} \left\{ \arctan \left(\frac{\cos(\theta_T)}{\tan(\phi_T)} \right) - (\phi - \phi_T) \right\} \quad (2)$$

$$\rho_1 = \frac{(n-1+q-0.25)\lambda_g}{1-\xi \sin \theta_T \cos(\phi - \phi_T)} \quad (3)$$

$$\rho_2 = \frac{(n-1+q+0.25)\lambda_g}{1-\xi \sin \theta_T \cos(\phi - \phi_T)} \quad (4)$$

$$\text{where } \xi = \frac{1}{\sqrt{\epsilon_{r1}}}$$

$$S_\rho = \frac{\lambda_g}{1-\xi \sin \theta_T \cos(\phi - \phi_T)} \quad (5)$$

$$S_\phi = \frac{2\pi\lambda_g}{\sqrt{1-\xi^2 \sin^2 \theta_T}} \frac{q}{p} \quad (6)$$

$$L_{\text{rad}} = (4.9876 \times 10^{-3} \rho) \frac{12.5 \times 10^9}{f_0} \quad (7)$$

Table 2 Design Parameters of the slots pairs [1,3]

Parameters	Symbols
Inclination angle of Slot 1	θ_1
Inclination angle of Slot 2	θ_2
Beam squint angle in the elevation direction	θ_T
Azimuth angle of Slot 1 and Slot 2 position	ϕ
Beam squint angle in azimuth direction	ϕ_T
Distance of a slot 1 from the center point of antennas	ρ_1
Distance of a slot 2 from the center point of antennas	ρ_2
Number of slot pairs in the first ring	n
Integer numbers (1, 2, 3...) that express the distance of innermost ring from the center of antennas	q
Distance between two adjacent unit radiators located in two different rings (distance in the radial direction)	S_ρ
distance between two adjacent unit radiators in the same ring (distance in azimuth direction)	S_ϕ

After simulating all the models and their cut versions, we chose and fabricated the three best models. Fig. 7 depicts the fabricated models for the full (a), half (b), and quarter (c) RLSAs as well as their feeder (d). The prototypes were measured to verify the simulation results (see Fig 8 for measurement activities).

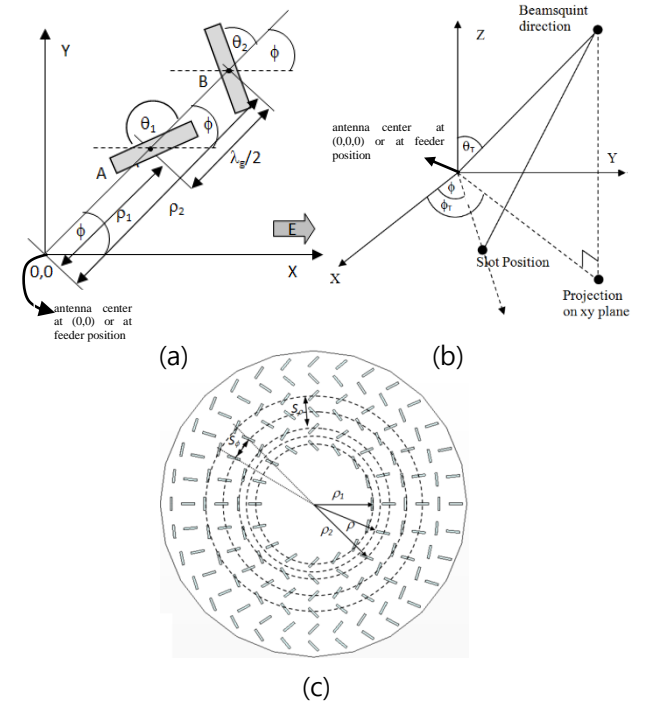

Fig. 6. (a) slots pairs along with all parameter in x-y plane (b) slots positions and their relations to beam direction in x-y-z (c) distance between slots in radial and azimuth directions [1,3]

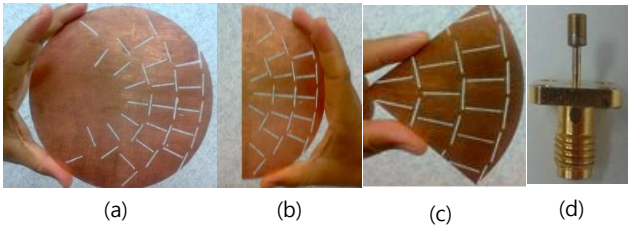

Fig. 7. A prototype of the (a) full RLSA, (b) half RLSA, (c) quarter RLSA, and (d) feeder

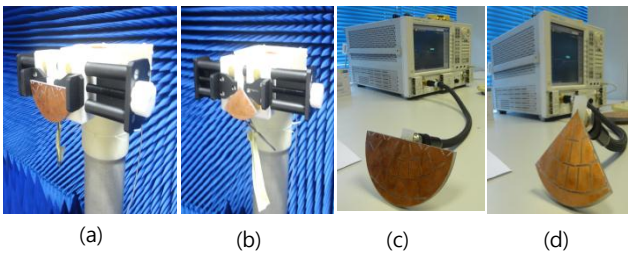

Fig. 8. Measurement of the prototypes (a) and (b) in an anechoic chamber, (c) and (d) using a network analyzer.

IV. RESULTS AND DISCUSSION

1. Reflection Coefficients and Bandwidths

Fig. 9 illustrates the reflection coefficient of the antenna models for various beamsquint values. From this figure, we observe that the quarter RLSAs have a lower reflection coefficient and wider bandwidth compared to those of the half RLSAs. We also observe that the half RLSAs have a lower reflection coefficient and wider bandwidth compared to those of the full RLSAs. We have determined these results because the quarter RLSAs have higher power density than the half RLSAs, and the half RLSAs have higher power density than the full RLSAs. Since higher power density will result in a smaller amount of remaining power in the antenna perimeter, higher power density antennas will have a smaller reflection coefficient and wider bandwidth compared to lower power density antennas, as has been explained in Section II.

Based on the above results, we conclude that we can design small RLSAs with a radius less than 75 mm. This is done by cutting an RLSA with a 75 mm radius into half and quarter RLSAs, the area of which is equal to a full RLSA, with radii of 53 mm and 37 mm. Furthermore, with the cut RLSAs, we additionally benefit from widened bandwidth and lower reflections.

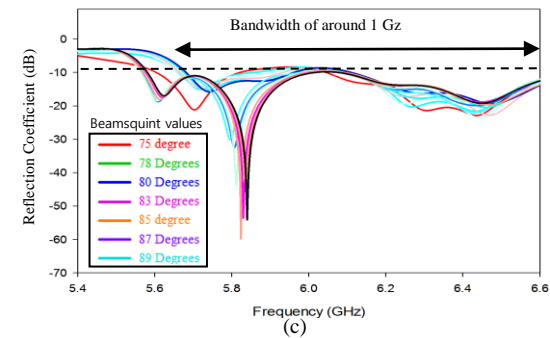
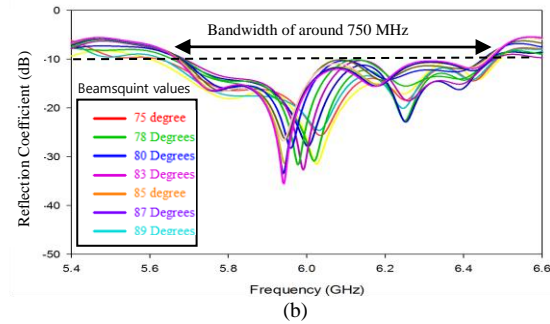
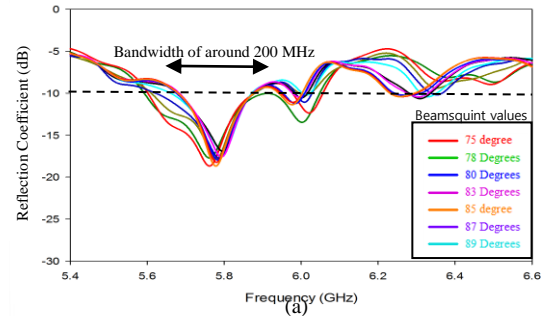

Fig. 9. Reflection coefficients for various beamsquint values of the (a) full RLSAs, (b) half RLSAs, and (c) quarter RLSAs

2. Gains

Fig. 10 displays the antenna gains for various beamsquint values for the quarter RLSAs, the half RLSAs, and the full RLSAs. We observe that, on average, the quarter RLSAs have a gain about 1 dB lower than that of the full RLSAs, whereas the quarter RLSAs should have a gain 6 dB (4 times) lower than that of the full RLSA as a consequence of their four-fold size reduction. This only 1 dB difference is due to the effect of higher power density that the quarter RLSAs have.

An interesting result is that, on average, the half RLSAs have a 1 dB higher gain than that of the full RLSAs, whereas the half RLSAs should have a gain 3 dB (2 times) lower than that of the full RLSAs. This is because two reasons. Firstly, if we observe Fig 5(a) and (b), the half RLSA and the full RLSA have nearly the

same number of slots, so their gain should be more or less the same. Secondly, the half RLSAs are able to radiate denser power than the full RLSAs as the effect of higher power density that the half RLSAs have, as discussed in Section II. These two causes make the gain of the half RLSA higher than the gain of the full RLSA.

Based on the above results, we conclude that, with the cut RLSAs, we additionally benefit from the maintained gain, which increases about 1 dB and decreases only 1 dB for the half RLSA and the quarter RLSA, respectively. This is notable, as theoretically the gain in the half and quarter RLSAs should decrease by 3 dB and 6 dB, respectively, due to their size reductions.

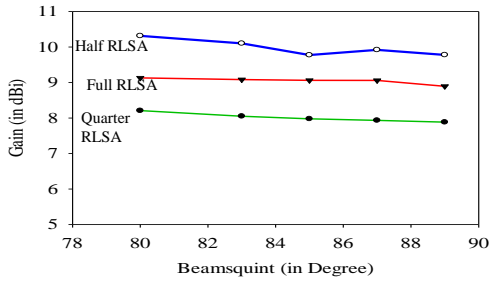

Fig. 10. Gain for various beamsquint values

3. The Half RLSA and Other Small RLSA Antennas Comparison

Comparisons of the area and the gain of the half RLSA against other small RLSA antennas are listed in Table 3. We observe that although the area of the half RLSA is the smallest, the gain is still the best. As an example, compared to the antenna in reference [22], the area of the half RLSA is 5.74 times smaller. Since theoretically gains would decrease linearly by the decrease of areas, so the gain of the half RLSA should be 5.74 times smaller, but the gain is only 4.47 times smaller. We also observe the similar results for other comparisons. The extreme case is for reference 17. Although the area of the half RLSA is two times smaller, the gain is 1.41 times higher (0.707 smaller). Despite all the result, the research aim is not to increase gains, but to result smaller RLSA antennas with low reflections and sufficient gains.

Table 3

Comparison of other small RLSA antennas against the half RLSA

References	Radii (cm)/ areas (cm ²)	Areas of other small RLSA antennas compared to the half RLSA antenna (Times)	Gains (dBi)	Gain of other small RLSA antennas compared to the half RLSA antenna (times)
17	7.5 / 176.62	2	9	0.707
18	7.5 / 176.62	2	12	1.41
22	12.7 / 506.45	5.74	17	4.47
23	14 / 615.44	7	18.4	6.17
24	11.5 / 412.56	4.7	17.28	4.76
25	12.3 / 475.05	5.4	17.53	5.05
26	10.7 / 359.50	4.07	16.25	3.76

4. Simulation and Measurement Comparison

Fig. 11 plots the reflection coefficients for both the simulation and measurement results. We observe that the half and quarter RLSAs have lower reflection coefficients and wider bandwidths compared to those of the full RLSA.

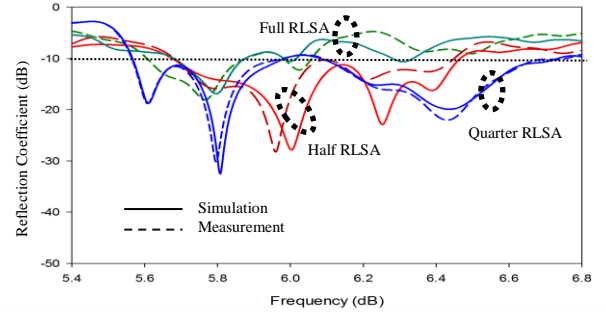

Fig. 11. Measurement and simulation result of the reflection coefficient

Fig. 12 depicts the radiation pattern for both the measurement and simulation results, showing that the half RLSA has a higher gain (10.5 dBi) compared to that of the full (9.1 dBi) and quarter RLSAs (8.1 dBi).

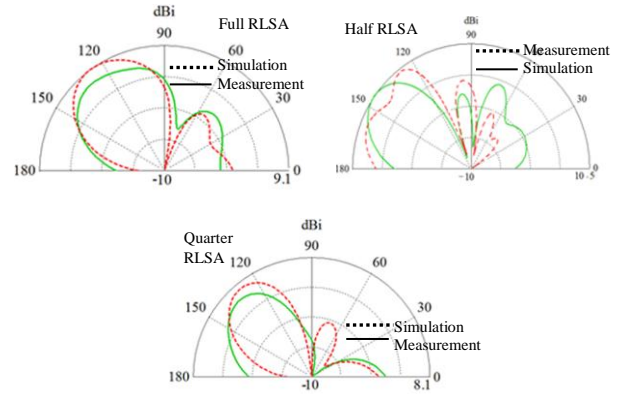

Fig. 12. Measurement and simulation results of the radiation pattern

Figs. 11 and 12 illustrate that the simulation results correspond with the measurement results. The slight deviation in the measurement results is due to imperfections in fabricating the prototypes, especially in printing the radiating element's design, drilling the antenna's feeder hole at the exact position, and soldering the head disc at the correct position.

Finally, based on the simulation and measurement results, we have verified our hypothesis that the cutting technique is effective for designing small low reflection RLSA antennas without significantly decreasing gain. These antennas have an area that is equal to full RLSA antennas, with radii of 53 mm and 37 mm. Furthermore, we demonstrated that, by cutting RLSA antennas, we even achieve a wider bandwidth.

V. CONCLUSIONS

We introduced a technique of cutting RLSA antennas to create small low reflection RLSAs. We demonstrated that this technique could be used to construct the smallest RLSA antennas ever with a size equal in area to full RLSAs, with radii of 53 mm and 37 mm for half RLSAs and quarter RLSAs, respectively, without significantly reducing gain; in fact, in one case (e.g., a half cut), the gain increased by about 1 dB. We also revealed that the designed small RLSAs have wider bandwidth and a lower reflection coefficient. This technique is expected to be a significant step in producing small low reflection RLSA antennas with sufficient gains for small devices such as wireless bridges. The antenna designed in this research was low profile just like microstrip antennas but better due to its well-known high efficiency. Therefore, it is possible to use it as an alternative for microstrip antennas. Future research is needed to apply this technique to design small RLSA antennas for other antennas radii and other frequencies.

REFERENCES

- [1] M. Ando, K. Sakurai, N. Goto, K. Arimura, Y. Ito, "Radial Line Slot Antenna for 12 GHz Satellite TV Reception." *IEEE Transactions on Antennas and Propagation*. Vol.33, no.12, pp. 1347-1353, 1995.
- [2] M. Takahashi, J-i. Takada, M. Ando, N. Goto, "A slot design for uniform aperture field distribution in single-layered radial line slot antennas," *IEEE Transactions on Antennas and Propagation*, vol.39, no.7, pp. 954-959, 1991.
- [3] P. W. Davis, "Experimental investigations into a linearly polarized radial slot antenna for DBS TV in Australia," *IEEE Transactions on Antennas and Propagation*, vol.45, no.7, pp. 1123-1129, 1997.
- [4] M. Ando, T. Numata, J-i, Takada, N. Goto, "Linearly polarized radial line slot antenna," *IEEE Transactions on Antennas and Propagation*, vol.36, no.12, pp. 1675-1680, 1988.
- [5] J. M. Fernández González, P. Padilla, G. Expósito-Domínguez, and M. Sierra-Castañer, "Lightweight portable planar slot array antenna for satellite communications in x-band," *IEEE Antennas and Wireless Propagation Letter*, vol.10, pp. 1409-1412, 2011.
- [6] J.-i. Takada, M. Ando, N. Goto, "A reflection cancelling slot set in a linearly polarized radial line slot antenna," *IEEE Transactions on Antennas and Propagation*, vol.40, no.4, pp.433-438, 1992.
- [7] H. Sasazawa, Y. Oshima, K. Sakurai, M. Ando, N. Goto, "Slot coupling in a radial line slot antenna for 12-GHz band satellite TV reception," *IEEE Transactions on Antennas and Propagation*, vol.36, no.9, pp. 1221-1226, 1988.
- [8] M. Sierra-Castañer, M. Sierra-Pérez, M. Vera-Isasa, "Low-cost monopulse radial line slot antenna," *IEEE Transactions on Antennas and Propagation*, vol.51, no.3, pp. 256-263, 2003.
- [9] Y. Wang, H. Xiao, G. Lu, J. Lin, T. Li, "The investigation for a circularly polarized radial line slot antenna with low side lobes and high gain," *In Proc Microwave and Millimeter Wave Technology (ICMMT)*, pp. 1226-1227, 2012.
- [10] Y. Kim, J. Lee, H. Chae, J. Park, S.C. Kim, S. Nam, "60 GHz band radial line slot array antenna fed by rectangular waveguide," *Electronics Letters*. Vol.38, no.2, pp.59-60, 2002.
- [11] K. Sudo, A. Akiyama, J. Hirokawa, M. Ando, "A millimeter-wave radial line slot antenna fed by a rectangular waveguide through a ring slot," *In Proc. IEICE Transactions on Electronics*, pp. 1521-1527, 2001.
- [12] R. Jin, H. Zhu, M. Ando, M, "A feeding circuit with CPW for CA-RLSA," *IEEE Transactions on Antennas and Propagation*, vol.49, no.12, pp. 1862-1867, 2001.
- [13] J.-i. Takada, T. Yamamoto, M. Ando, N. Goto, "Circularly polarized multibeam radial line slot antennas for mobile satellite communication," *in Proc. IEEE Antennas and Propagation Society, AP-S International Symposium (Digest)*, pp. 1430-1433, 1995.
- [14] K. S. Bialkowski and S. Zagriatski, "Investigations into a dual band 2.4/5.2GHz antenna for WLAN applications," *in Proc. 15th International Conference on Microwaves, Radar and Wireless Communications, MIKON*, pp. 660-663, 2004.
- [15] S. Zagriatski and M. E. Bialkowski, "Circularly polarised radial line slot array antenna for wireless lan access point," *in Proc. 15th International Conference on Microwaves, Radar and Wireless Communications, MIKON*, pp. 649-652, 2004.
- [16] T. A. Rahman, M. I. Imran, P. S. Wei, J. Ahmad, A. G. C. Wahab, "A study on effectiveness of FR4 as a dielectric material for radial line slot array antenna for wireless backhaul application," *In Proc. The 17th Asia Pacific Conference on Communications*, pp. 385-388, 2011.
- [17] T. Purnamirza, T. A. Rahman, M. H. Jamaluddin, "The extreme beamsquint technique to minimize the reflection coefficient of very small aperture radial line slot array antennas," *Journal of Electromagnetic Waves and Applications*, vol.26, no.17-18, pp. 2267-2276, 2012.
- [18] T. Purnamirza and T. A. Rahman, "A Novel Technique in Simplifying the Fabrication Process and in Improving the Reflection Coefficient of the Linear Polarized Radial Line Slot Array (LP-RLSA)

Antennas,” *Journal on Electromagnetic Wave and Application*, vol.26, no.4, pp. 535-548, 2012.

- [19] A. Akiyama, *et al.*, “Numerical optimisation of slot parameters for a concentric array radial line slot antenna,” In *Proc. IEE Proceedings: Microwaves, Antennas and Propagation*, pp. 141-145, 1998.
- [20] A. Akiyama, *et al.*, “Design of radial line slot antennas for millimeter wave wireless LAN,” in *Proc. IEEE Antennas and Propagation Society, AP-S International Symposium (Digest)*, pp. 2516-2519, 1997.
- [21] J. Hirokawa, *et al.*, “Matching slot pair for a circularly-polarised slotted waveguide array,” *IEE Proc. Microwaves, Antennas and Propagation*, pp. 367-371, 1990.
- [22] T. Purnamirza, S. Hasbi, I.M. Ibrahim, Mulyono, F. Amillia, D. Rahmi, “A Radial Line Slot Array (RLSA) Antenna with the Specifications of 16 dBi Outdoor patch Antenna. *Journal of Telkomnika*. [online]. 16(1). pp 46-62, 2018.
- [23] T. Purnamirza, D. Kristanto, I.M. Ibrahim, “A Design of Compact Radial Line Slot Array (RLSA) Antenna for Wi-Fi Market Needs,” *Journal of Progress in Electromagnetics Research Letters (PIER-L)*, vol.64, pp 21-28, 2016.
- [24] T. Purnamirza, P. Prowadi, I.M. Ibrahim, “Small Radial Line Slot Array (RLSA) Antennas for Wi-Fi 5.8 GHz Devices,” *International Journal on Communications Antenna and Propagation*. [Online].vol.7, no.5, pp 397-402, 2017.
- [25] T.Purnamirza, P. Budikesuma, I.M. Ibrahim, D. Rahmi, R.Susanti, “A Small RLSA Antenna Utilizing the Specification of Back Fires 17 dBi LAN Antennas,” *Journal of Telkomnika*, vol.16, no.6, pp 2871-2879, 2018.
- [26] T.Purnamirza, M.Ralibi, I.M.Ibrahim, F.Amillia, D.Rahmi, Sutoyo, A Design of Radial Line Slot Array Antennas Using the Specification of Panel Antennas. *Journal of Telkomnika*, vol.17, no.6, pp 3066-3072, 2019.



Teddy Purnamirza was born in Pekanbaru Indonesia on 30th October 1974. He received his bachelor degree in electrical engineering from STT Telkom (currently Telkom University), Bandung, West Java, Indonesia, in 2000. He received his master and doctoral degree from UTM, Johor, Malaysia, both in electrical engineering, in 2005 and 2013, respectively.

He joined Informatic Engineering Department UIN Suska in 2000. From 2000 to 2003, he was head of informatics laboratory. He joined Electrical Engineering Department UIN Suska in 2003. From 2005 to 2007, he was head of computer laboratory. From 2007 to 2010, he was head of Electrical Engineering Department in UIN Suska. From 2013 to 2018, he was vice dean for academic affairs and institution development at Faculty of

Science and Technology UIN Suska. He is now serving as associate professor in UIN Suska.

He has published three books, one book chapter, fifteen journal papers and 4 conference papers. His research interests are antennas and propagations.



Imran Muhammad Ibrahim was born in Kedah, Malaysia on 23rd June 1976. He received his bachelor degree, master and doctoral degree from UTM Malaysia, all in electrical engineering, in 2000, 2005, and 2016, respectively. He is now serving as a Senior Lecturer in UTeM.

He has published more than 30 journals and conference papers. His research interests are antennas and propagations. Dr. Imran is a member of IEEE Malaysia and Institute of Engineers Malaysia.



Rika Susanti was born in Pekanbaru, Indonesia on 31st July 1977. She received her bachelor degree and master degree, both in electrical engineering, from Diponegoro University, Semarang, center Java, Indonesia, in 2003 and UTM, Johor, Malaysia in 2010, respectively.

She joined in Electrical Engineering Department of UIN Suska since 2004. She is now serving as senior lecturer in UIN Suska.

She has published three books, two journal papers and nine conference papers. Her main research interest is in area of optical communication system.



Sutoyo was born in Kampar, Indonesia on 2nd December 1984. He received his bachelor degree in electrical Engineering from UIN Suska in 2008. He received his master from Institut Teknologi Sepuluh November (ITS), Surabaya, East Java, Indonesia, in 2012.

He joined Electrical Engineering Department UIN Suska in 2008. He is now serving as a senior lecturer in UIN Suska and head of quality assurance committee in Faculty of science and technology UIN Suska.

He has published two books, two journal papers and three conference papers. His research interests are antennas and propagations.



Mulyono was born in Dumai Indonesia on 15th November 1985. He received his bachelor degree in electrical engineering from UIN Suska Riau in 2008. He received his master from Institut Teknologi Sepuluh November (ITS), Surabaya, East Java, Indonesia, in 2012.

He joined Electrical Engineering Department UIN Suska in 2008. He is now serving as senior lecturer in UIN Suska and secretary of Electrical engineering department UIN Suska.

He has published two books, two journal papers and four conference papers. His research interest is wireless communication.



Hasdi Radiles was born in Pekanbaru on 9th September 1977. He received his bachelor and master degree in electrical engineering from STT Telkom (currently Telkom University), Bandung, West Java, Indonesia, in 2000 and 2005, respectively.

He worked at Huawei Tech Investment - Indonesia as a professional in 3G Radio Network Planning and Optimization. Since 2010, he joined Electrical Engineering Department UIN Suska Riau. His research interests are antennas and propagations.



Depriwana Rahmi was born in Pekanbaru Indonesia on 6th March 1981. He received his bachelor degree and master degree from Universitas Riau, Pekanbaru, Riau and UTM Malaysia, Johor, Malaysia, in 1999 and 2015, respectively.

She joined Mathematic Education Department UIN Suska in 2006. She is now serving as senior lecturer in UIN Suska.

She has published four books, eight journal papers and four conference papers. Her research interest is statistic.